



# LYR

## CONFIGURABLE HYBRID CONTROL CENTER

IN NORSE MYTHOLOGY, LYR IS MENGLAD'S HALL IN JOTUNHEIM.  
BOTH ARE GIANTS IN THEIR OWN RIGHT.  
BUYING LYR WON'T GET YOU AN IN WITH ODIN.  
AND NO, IT WON'T GET YOU INTO VALHALLA, EITHER.  
YEAH, WE KNOW, CHEAP SCHIIT BASTARDS.  
BUT WHAT CAN YOU DO?

## OWNER'S MANUAL

# INTRODUCTION

---

Lyr 3 is the second in our line of configurable desktop control centers. It combines a highly capable hybrid power amplifier and preamp with a modular architecture that allows you to add a DAC, phono preamp, or any future modules we come up with. Forget the built-in obsolescence of other amp/DACs, and enjoy your time in Lyr!

---

## WHAT'S IN THE BOX

- (1) Lyr 3
- (1) Power cord
- (0) Stick-on feet (they're pressed in!)



The following is required by the roughly 9,542 government agencies and regulations we have to comply with. If you have some common sense, they should seem pretty straightforward. In any case, read these instructions before proceeding farther, follow all instructions, and heed all warnings. Or else!

1. If you don't know how to install audio devices, get a qualified professional to help.
2. Never use this device near water, and clean only with a dry cloth.
3. Assure adequate ventilation, do not block any ventilation openings, or place near heat sources.
4. Use only the supplied power cord or suitable replacement. Route cords away from traffic areas and protect them from being pinched. Unplug the cord from the outlet if the apparatus is unused for a long period of time.
5. To prevent electric shock, do not use the plug with an extension cord, receptacle, or outlet unless blades can be fully inserted.
6. Refer all servicing to qualified service personnel. Service is required when the device has been damaged, including cord or plug damage, liquid has been spilled or objects have fallen into the device, the device has been exposed to rain or moisture, does not operate normally, or has been dropped.



**WARNING: TO REDUCE THE RISK OF FIRE OR ELECTRIC SHOCK, DO NOT EXPOSE THIS DEVICE TO RAIN OR MOISTURE.**

## GETTING STARTED

---

### CAUTION! Dangerous voltages inside!

1. **Insert the tube.** Carefully align the key in the tube base to the notch in the tube socket.



2. **Ensure tube is well-seated.** Push down firmly until the tube is seated on the tube socket.

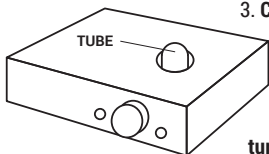

3. **Connect your source.**

Use high-quality RCA cables and a good source.

4. **Plug it in and turn it on.** The tube will glow after a few seconds,

and the relay will connect the output in about 40-50 seconds.

**If you have an optional DAC module,** you'll also need to connect your digital source.

a. Use a high-quality, USB 2.0-rated cable of 2M or less in length.

b. On some Windows machines, you may need drivers, available at [schiiit.com/drivers](http://schiiit.com/drivers).

**If you have the optional phono card,** you'll also need to connect your turntable.

a. Using short, high-quality, well-shielded cables, connect your turntable to the phono card inputs.

b. Also connect the turntable ground to the ground post with a short, sturdy wire.

c. Note that the phono preamp's gain is fixed at 42dB, input impedance is 47k, and load capacitance is 100pF.

## REPLACING TUBES

Lyr 3 accommodates any 6SN7, 6N8S or 5692 tube.

1. **Turn off and unplug the preamp.** Wait a while for the tube to cool.

2. **Carefully extract the tube** by gently rocking it back and forth and pulling upwards.

3. **Carefully insert the replacement tube.** Align the key to the notch and press down firmly until the tube is seated.

4. **Plug the preamp back in and turn it on.**

## CONTROLS

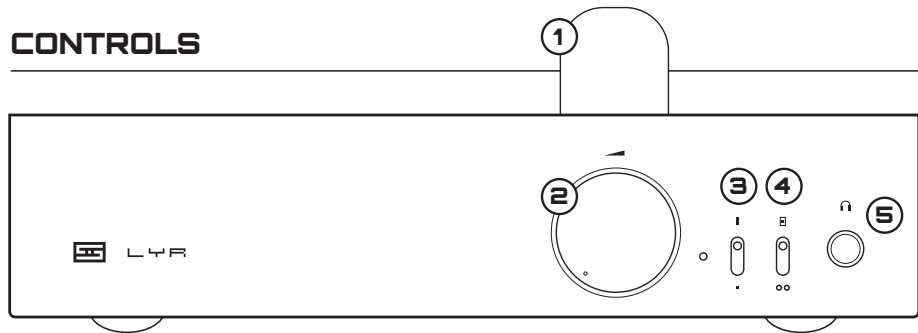

**1 Tube.** This guy gets plenty hot. Best not to grab it while it's running, or immediately after you turn the amp off. Also not a good pet suppository. Also keep kids away. You get it, right?

**2 Volume Knob.** Turn it to the right to make the music louder. Stop before it hurts. Or your headphones smoke. Seriously.

**3 Gain Switch.** Up is high gain. Down is low gain. No surprises here. Use low gain for sensitive headphones—that is, if you hear hiss or don't have enough volume control range.

**4 Input Switch.** Up selects the module input (DAC or phono). That is, if you have a module. If you don't have a module, up doesn't do anything. Down selects the rear panel analog RCA inputs.

**5 Headphone Jack.** Plug your headphones in here. There ain't no fancy balanced or fake-balanced connectors on this amp—it delivers full power through a standard 1/4" jack. If you have 1/8" jack headphones, get an adapter.

# CONNECTIONS

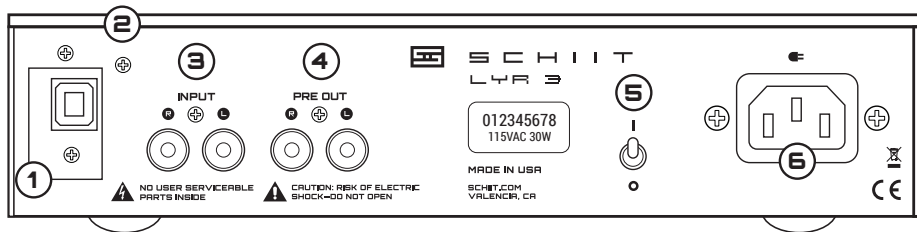

**1 Card Input.** If you have a module installed, the input for the module will be here. If you don't have a module installed, it will be covered.

**2 Ground Lug.** If you have a phono card installed, there will be a ground lug here. Connect to your turntable ground for minimum hum.

**3 RCA Input.** Connect your source here with high-quality RCA cables. Alternately, you can use cheapie cables, but if you have a problem, remember that we'll ask you to check cables first.

**4 Preamp Output.** Connect these to your powered monitors or speaker power amplifier with high-quality RCA cables. If your powered monitors have XLR inputs, you can use RCA to XLR cables to connect to them.

**5 On-Off Switch.** Up is on. Down is off. Nothing very complicated here.

**6 AC Input.** Plug the power cord in here. Plug the other end into an outlet of the correct voltage. Trying to run a 115V product on 230V will blow the fuse and generally make for a bad, bad day.

## FAQ

---

### **I hear hum through the headphones.**

Some small amount of hum may be noticeable on most tube amplifiers, especially with high-sensitivity headphones. Switch to low gain, and ask yourself why you're using IEMs with a 6W amp.

### **No, I mean a LOT of hum.**

You may have a ground loop. To fix a ground loop, try a ground loop isolator or an EbTech HumX. If it's low-level hum and noise, you can use Lo gain to reduce it.

### **There's no sound for a while after I turn Lyr 3 on.**

That's perfectly normal. Lyr 3 has a built in start-up delay (and instant shut-down.) It's set to 40-45 seconds to let the tube come up and the bias servo to stabilize.

### **There's no sound with the input switch in the top position.**

Do you have the optional DAC or phono card? If you don't, you won't get any sound.

### **I get weird noises when I use my cheapie earbuds that have volume control on them.**

Right. Those are TRRS headphones. You need a TRRS to TRS adapter for those.

### **Can I leave Lyr 3 on all the time?**

You can, but you'll be burning through tube life. Best to use octal LISST if you want to leave it on all the time.

### **My computer doesn't see the DAC card via USB, what's up?**

Go to [schiit.com/faq/dac-problems](http://schiit.com/faq/dac-problems) and [schiit.com/faq/usb-problems](http://schiit.com/faq/usb-problems) for digital system troubleshooting.

### **I'm having hiss and hum from the phono card, how do I fix that?**

Start at [schiit.com/faq/phono-problems](http://schiit.com/faq/phono-problems) for phono troubleshooting tips.

### **It doesn't turn on, what do I do?**

Plug it in to a different AC socket. Ensure you are not currently in a blackout. Then email us if it still doesn't work.

## 5-YEAR LIMITED WARRANTY

---

Schiit Audio warrants to the original purchaser that this product shall be free from defects in material and workmanship for five (5) years from the date of purchase. If a defect covered by this warranty occurs during this period, Schiit Audio will repair the defective product, free of charge. Date of purchase will be based on customer receipts, otherwise date of manufacturing will be used.

If you believe you need warranty service, contact us first. Schiit Audio products sent back to us without a Return Authorization (RA) will be returned to the sender without repair. To contact us and obtain an RA, email [tech@schiiit.com](mailto:tech@schiiit.com).

Warranty Limitations. This warranty shall not apply if a product: (a) is modified or tampered with; (b) is damaged by negligence, accident, unreasonably use, or other causes unrelated to defective materials or workmanship, or (c) has had the serial number altered or removed.

Any implied warranties, including warranties of merchantability and fitness for a particular purpose, are hereby limited in duration to the warranty period of 2 years. In no event shall Schiit Audio be liable for consequential or incidental damages resulting from the breach of any implied or expressed warranties. Some states do not allow these limitations, so they may not apply to you. You may also have other rights which vary from state to state or province to province.



---

SCHITT.COM  
TECH@SCHITT.COM